

LAND ACQUISITION AND DISTRIBUTION PROCESS

pursuant to Administrative Order No. 2, Series of 2005, as amended by AO 4, S. 2007

A. Identification, Documentation & Survey

B. Review & Completion of Documents

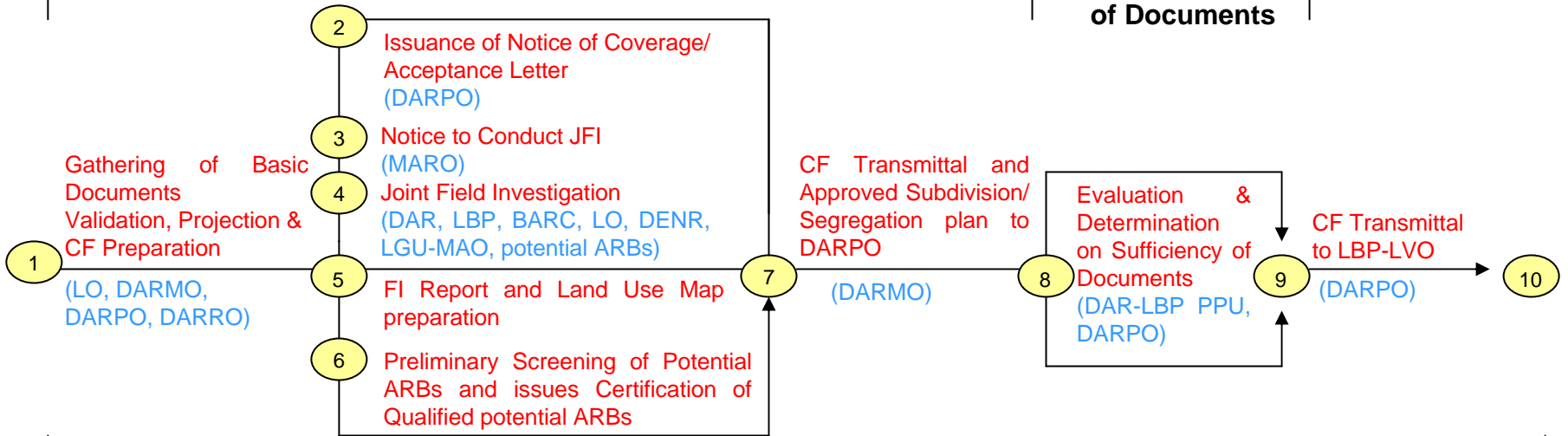

C. Land Valuation & Compensation

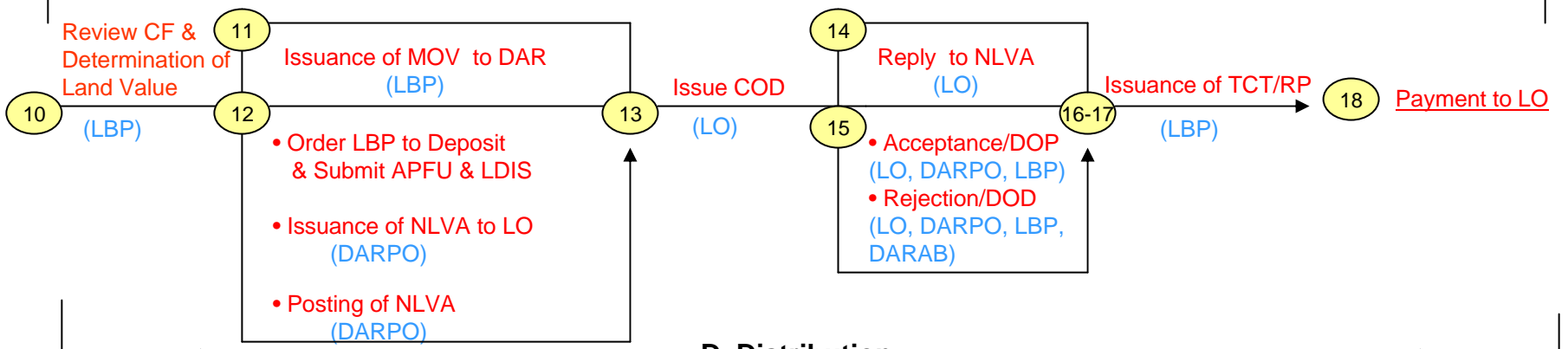

D. Distribution

