

LAND ACQUISITION AND DISTRIBUTION PROCESS

pursuant to Administrative Order No. 2, Series of 2005, as amended by A.O. 4, S. 2007

A. Identification, Documentation & Survey

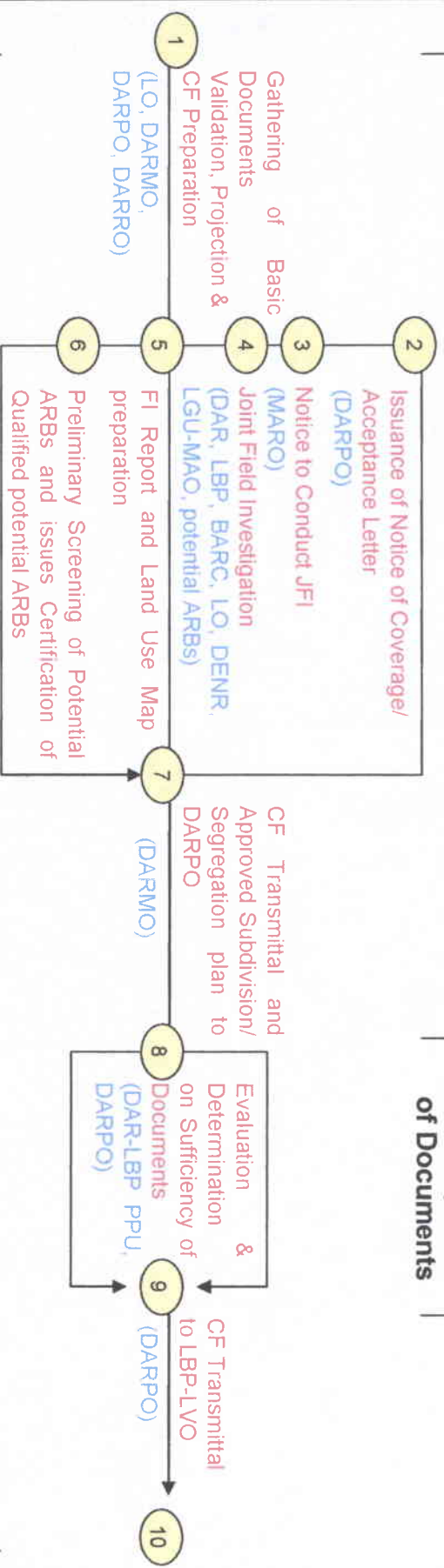

B. Review & Completion of Documents

C. Land Valuation & Compensation

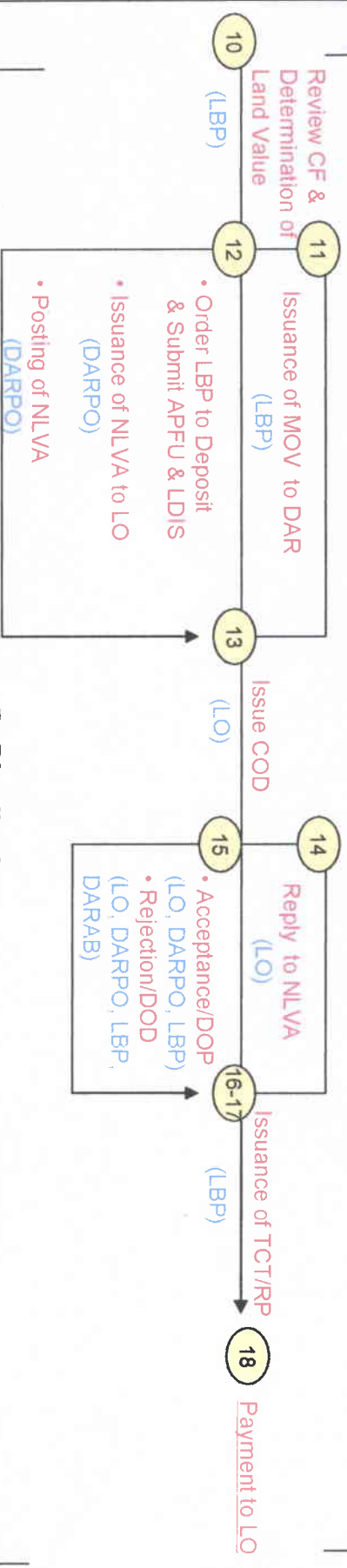

D. Distribution



CHECKLIST OF REQUIRED DOCUMENTS

For Titled Properties:

- Notarized Letter Offer (CARP-LA FORM NO. 2)
- ROD certified copy/ies OCT/TCT
- Assessor's certified copy of Tax Declaration
- Copy of Approved Survey Plan or Sketch/Lot Plan of the property certified by a registered Geodetic Engineer
- Latest ID picture or photocopy of any valid ID, with signature and picture, of the registered owner/heirs

For Untitled Properties:

- Notarized Letter Offer (CARP-LA FORM NO. 2)
- Certification of the DENR-CENRO or Regional Technical Director, Lands Management Service, pursuant to DAR-DENR-LBP Joint Memorandum Circular No. 12, Series of 1994, Joint DENR-DAR Administrative Order No. 2003-1 and applicable rules and regulations
- Approved Survey Plan (ASP). If ASP is not available, a Sketch Plan and Technical Description duly approved by DENR
- Certified copy of the present Tax Declaration from the Assessor's file in the name of the claimant with correct lot numbers and area per approved plan
- Instruments of acquisition covering the subject property, such as deeds of sale, donation, transfer, etc. in favor of claimant and those of his predecessor/s-in-interest
- Certification of the Assessor concerned showing the Tax Declaration issued, the declarant/s, the area covered, and the basis for the issuances and cancellations thereof up to the Tax Declaration issued in the name of the claimant, as well as any existing liens on the present and previous Tax Declaration
- Certification from the Clerk of Court concerned whether or not the property/ies identified in the plan is/are covered by land registration proceedings or civil case, and if the same is used as bond in other Court actions.
- Certification from the Assessors' Office concerned to the effect that as per their records, the property/ies as appearing in the approved survey plan is/are free from all liens and encumbrances
- LRA Certification that the property is not within any decreed or titled property
- Latest ID picture or photocopy of any valid ID, with signature and picture, of the landowner/heirs

LETTER OFFER

Address _____
Date _____

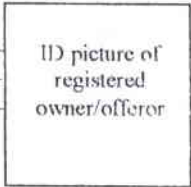

The Honorable Secretary
Department of Land Reform
Diliman, Quezon City

Thru: The Provincial Agrarian Reform Officer

Sir:

In support of the Comprehensive Agrarian Reform Program of the government, I have the honor to voluntarily offer to sell to the Republic of the Philippines my land, including the improvements thereon, described as follows:

OCT/TCT No. _____ Total Area per Title/ID, in hectares (has.) _____
Tax Dec. No. _____ Area offered (has.) _____
Lot No./Survey No. _____
Location _____

I hereby declare that the land is productive or suitable to agriculture. My offer is as follows:

Land (including crops) P _____/ha or a total amount of P _____
Improvements (non-crops such as mills, bodega, etc.) P _____

May I likewise inform you, that:

- I am exercising my right of retention to the extent of _____ has.
- I am nominating my _____ child/children as preferred beneficiaries subject to the requirements of Section 6 of R.A. No. 6657.
- I am not exercising my right of retention.

I have been informed of and fully comprehend the terms and conditions as provided for by law and applicable guidelines for the DLR, LBP, DENR and BARC, and other representatives to enter my property for purposes of inspection, verification, studies leading to the redistribution of the property to qualified beneficiaries.

I hereby authorize DLR to take immediate possession of my land described above after LBP has deposited the land compensation in my name.

I am attaching herewith a certified copy of the OCT/TCT and other ownership documents:

Very truly yours,

Signature over Printed Name of Landowner
or Authorized Representative (with SPA to sell
or Board Resolution to sell as the case may be)

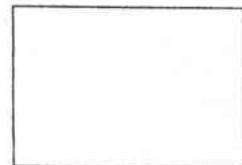

RIGHT THUMB MARK

CONFORME: SPOUSE/CO-OWNERS (if applicable)

Signature over printed name

ACKNOWLEDGEMENT

REPUBLIC OF THE PHILIPPINES)
PROVINCE OF _____)S.S.
CITY/MUNICIPALITY OF _____

BEFORE ME, on this, _____ day of _____ in _____, at _____ personally appeared _____ in his/her capacity as _____ of the _____ with Community Tax Certificate No. _____ issued at _____ on _____ known to me and to me known to be the same person who accomplished the foregoing LETTER-OFFER in his/her own free and voluntary act and deed as well as that of the corporation he/she represents.

WITNESS MY HAND AND SEAL, on the date and at the place above written.

Notary Public

Doc.No _____
Page No. _____
Book No. _____
Series of _____